

Test Report

On Behalf of

Zhejiang Leader Industry & TradeCo.,Ltd.

Mobile platform stairs

**Model: AY-PS30012, AY-PS12505, AY-PS15006, AY-PS17507,
AY-PS20008, AY-PS22509, AY-PS25010, AY-PS27511,**

Prepared For : Zhejiang Leader Industry & TradeCo.,Ltd.

**Building 2, No.2-1 Industrial Avenue, Silukou
Shangcun, LongshanTown, Jinhua City, Zhejiang
Province**



Prepared By : Eport (Shenzhen) Electronics Co., Ltd.

**Rm 5-508, Haibin City Plaza, 46 Section, Baoan
District, Shenzhen, P.R.C**

Date of Test : April 15-23, 2025
Date of Report : April 24-25, 2025
Report Number : EPTC-LD-S2504618

Test Report
EN 131-7:2013
Ladders –
Part 7: Mobile ladders with platform

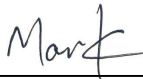
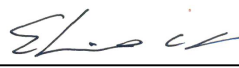
Testing laboratory	Eport (Shenzhen) Electronics Co., Ltd.
Address	Rm 5-508, Haibin City Plaza, 46 Section, Baoan District, Shenzhen, P.R.C
Testing location	Eport (Shenzhen) Electronics Co., Ltd. Rm 5-508, Haibin City Plaza, 46 Section, Baoan District, Shenzhen, P.R.C
Applicant	Zhejiang Leader Industry & TradeCo.,Ltd.
Address	Building 2, No.2-1 Industrial Avenue, Silukou Shangcun, LongshanTown, Jinhua City, Zhejiang Province
Standard	EN 131-7:2013
Result	Comply with: EN 131-7:2013
Procedure deviation	N.A.
Non-standard	N.A.
Type of verdict object	Mobile platform stairs
Trademark	---
Model/type reference	AY-PS30012
Max. Load	150 kg
Manufacturer	Zhejiang Leader Industry & TradeCo.,Ltd.
Address	Building 2, No.2-1 Industrial Avenue, Silukou Shangcun, LongshanTown, Jinhua City, Zhejiang Province
Material	Aluminum

Possible case verdicts :	
Case does not apply to the test object	: N/A (not applicable)
Case does not required by applicant and not conducted to the test object	: N/T (not tested)
Verdict object does meet the requirement	: P(ass)
Verdict object does not meet the requirement	: F(ail)
Name and address of the testing laboratory: <u>Eport (Shenzhen) Electronics Co., Ltd.</u> <u>Rm 5-508, Haibin City Plaza, 46 Section,</u> <u>Baoan District, Shenzhen, P.R.C</u>	
Reported by :	<div style="display: flex; justify-content: space-between;"> <div style="text-align: center;">  _____ Signature </div> <div style="text-align: center;"> April 25, 2025 _____ Date </div> </div>
Approved by :	<div style="display: flex; justify-content: space-between;"> <div style="text-align: center;"> <u>Mark Zhang / Project Engineer</u> Name and Title  _____ Signature </div> <div style="text-align: center;">  _____ Date </div> </div> <div style="text-align: center; margin-top: 10px;"> <u>Eliza Chen / Manager</u> Name and Title </div>

General remarks:	
-------------------------	--

"(see remark #)" refers to a remark appended to the report.

"(see appended table)" refers to a table appended to the report.

Throughout this report a comma is used as the decimal separator.

The test results presented in this report relate only to the object tested.

This report shall not be reproduced except in full without the written approval of the testing laboratory.

Remark 1:

1. All tests were conducted on AY-PS30012 unless otherwise special.
2. All models are the same load capacity (max.150kg).
3. AY-PS12505, The AY-PS15006, AY-PS17507, AY-PS20008, AY-PS22509, AY-PS25010, AY-PS27511 all models are same material but identical except different numbers of steps and height and the shape. Other test results are consistent with model AY-PS30012.

Marking label

Mobile platform stairs	
Model: AY-PS30012	
Standard: EN 131-7: 2013	
Max Load: 150Kg	
Zhejiang Leader Industry & TradeCo., Ltd.	
Made in China	Manufacture date: April, 2025



General notes: local language will be used if put the ladders in the local market.

Summary of testing:

The clauses 4.2.1; 4.2.2; 4.3-welding; 5.16; 5.17 of EN 131-2 and partially requirements of label and instruction were not tested in this report.

Except the not tested items; the tested objects comply with the other requirements as specified for the standards mentioned on page one.

Otherwise specified, the testing was done on model AY-PS30012.

Photos of the tested object



EN 131-7: 2013				
Clause	Requirement	Test	Result - Remark	Verdict
3	TERMS AND DEFINITIONS			-
	Type of ladder.....:		Platform standing rung ladder. With platform and protection guard and handrails. Width of rungs: 78 mm. See General product information and product photos.	-
4	REQUIREMENTS			-
4.1	General			-
	A mobile platform ladder shall be designed and manufactured to prevent accidental slips of product and/or user.			P
	The marking shall be legible and durable. The durability of the marking shall be verified.			P
	Wide rungs/steps and platforms shall be designed to be horizontal when the product is used on a flat floor.			P
	Wide rungs, rungs, steps and platforms made of metal or plastics shall have a textured surface on the working face to reduce slipping. The contact surface of the coverings shall adhere firmly to the rungs or steps.			P
4.2 (4.4 of EN 131-2)	Surface finishes			-
	This requirement shall be according EN 131-2.		Free of burrs. Corrosion protected. Permeable to water vapour. See parts of EN 131-2.	-
	The coating of wooden parts shall be transparent and permeable to water vapour. This does not apply to platform components manufactured from plywood materials.		No wooden parts.	N/A
(4.4 of EN 131-2)	In order to avoid injuries, accessible edges, corners, and protruding parts shall be free of burrs, for example chamfered or rounded.			P
	Metal parts susceptible to corrosion shall be protected by means of a paint coating or other coating.			P
	Under normal conditions aluminium alloys are not susceptible to corrosion.		Aluminium alloys.	P
	Wooden parts shall be smoothed and coated on all sides.		No wooden parts.	N/A
	The coating shall be transparent and permeable to water vapour.			N/A

EN 131-7: 2013				
Clause	Requirement	Test	Result - Remark	Verdict
4.3 (4.2 of EN 131-2)	Materials			-
4.3.1	General			-
	The requirements on materials shall be according to EN 131-2 apply unless otherwise stated.		See parts of EN 131-2.	-
(4.2 of EN 131-2)	Materials			-
4.2.1	Aluminium — alloy			-
	All load bearing parts made of aluminium alloy shall have an elongation A5 at rupture measured according to EN ISO 6892-1 of minimum 5 %.			N/T
	All load bearing parts made of aluminium alloy shall have a thickness of at least 1,2 mm.			P
4.2.2	Steel			-
	If cold rolled steel or a special alloy-steel is used the ratio between 0,2 % yield-stress and ultimate strength ($R_p 0,2/R_m$) shall be lower than 0,92.			N/T
	All load bearing parts made of steel shall have a thickness of at least 1,0 mm.			P
4.2.3	Plastics			-
	Glass-fibre reinforced plastics shall be protected against penetration of water and dirt. The surface shall be smooth. The fibres shall be embedded. The Barcol hardness according to EN 59 shall be at least 35.			P
	The test methods and acceptance criteria for defining the characteristics of the composite and reinforced thermoplastic materials are given in 5.16.		See clause 5.16.	-
	Thermoplastic materials without reinforcements shall not be used for load bearing-elements.			P
	The minimum thickness for load-bearing elements made of thermoset plastics and composite material is 2 mm.		Glass-fibre reinforced plastics (composite material): 3 mm.	P
4.2.4	Timber		No timber used.	N/A
4.3.2	Wood used for the platform should be of durable quality and be suitable for both indoor and outdoor use.		Not wood.	N/A
	The coating shall be transparent and permeable to water vapour.			N/A
	Coatings applied to platform components manufactured from plywood materials shall be permeable to water but may be opaque.			N/A
	The surface of the platform shall be slip resistant.			N/A
4.4	Stabiliser			N/A

EN 131-7: 2013																					
Clause	Requirement	Test	Result - Remark	Verdict																	
	If the design makes stabilisers necessary to fulfil the stability test requirements, they shall be supplied with the ladder. It shall be clear that the product is meant to be used with stabilisers. Specific safety instruction shall be visible on the ladder and may be repeated on the stabilisers			N/A																	
4.5	Ballast			N/A																	
	If the design makes ballasts necessary to fulfil the stability test requirements, they shall be supplied with the ladder. It shall be clear that the product is meant to be used with a ballast. Specific safety instruction shall be visible on the ladder and may be repeated on the ballast.		No ballast.	N/A																	
5	DIMENSIONAL REQUIREMENTS			-																	
5.1	Ascending legs			P																	
5.1.1	Ascending legs with angle $60^\circ \leq \alpha \leq 75^\circ$ The dimensional requirements for ascending legs angle $60^\circ \leq \alpha \leq 75^\circ$ are shown in Table 2.		60°	P																	
	Table 2 — Dimensional requirements for ascending legs with angle $60^\circ \leq \alpha \leq 75^\circ$			P																	
		<table border="1"> <thead> <tr> <th></th> <th>b_1</th> <th>h</th> <th>g</th> <th>l_4</th> <th>l_5</th> </tr> </thead> <tbody> <tr> <td>min.</td> <td>400</td> <td></td> <td>20</td> <td>$0,5 \times l_5$</td> <td>230</td> </tr> <tr> <td>max.</td> <td></td> <td>5 000</td> <td></td> <td>$l_5 + 15$</td> <td>300</td> </tr> </tbody> </table>		b_1	h	g	l_4	l_5	min.	400		20	$0,5 \times l_5$	230	max.		5 000		$l_5 + 15$	300	
	b_1	h	g	l_4	l_5																
min.	400		20	$0,5 \times l_5$	230																
max.		5 000		$l_5 + 15$	300																
	b_1 (Min.: 400 mm)			P																	
	h (max. 5 000 mm)			P																	
	g (Min. 20 mm)			P																	
	l_4 (Min. 0,5 l_5 ; Max. $l_5 + 15$)		Meet the requirement	P																	
	l_5 (Min. 230 mm; Max. 300 mm)		Meet the requirement	P																	
	This product is ascended and descended facing the ladder.			P																	
	Handrails can be added to this product.			P																	
5.1.2	Ascending legs with angle $45^\circ \leq \alpha < 60^\circ$			N/A																	
5.2	Supporting legs			P																	
	The projection on the horizontal plan of the platform shall be within the contact points of the ladder with the ground within a maximum tolerance of 100 mm due to the possible eccentricity of the swivel casters or other design of the platform ladder.		Within the contact points.	P																	
	If the projection on the horizontal plan of the platform within the contact points of the ladder with the ground is greater than 100 mm, additional precautions are taken regarding the stability. The stability test described in 6.7 is not suitable for such described products			N/A																	

EN 131-7: 2013

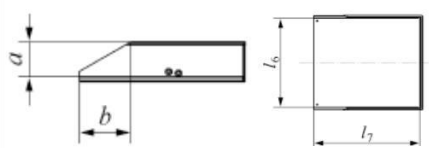
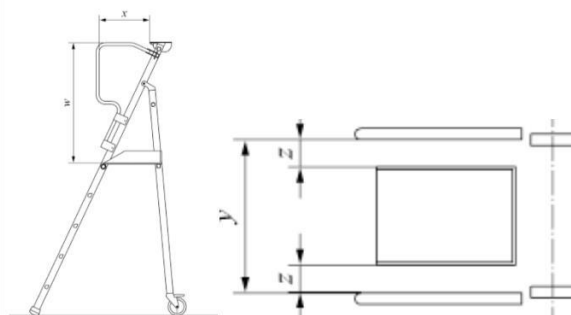
Clause	Requirement	Test	Result - Remark	Verdict															
5.3	Platform and toe board			P															
	The platform shall be permanently fixed to the ladder. The platform shall be equipped with toe board on all sides where access is not permitted, except the ascending side.		All models with same platform and toe board construction.	P															
	The dimensions (width and length) shall be between 400 mm and 1 000 mm (see Table 4).			P															
	The platform shall be equipped with a solid toe board such that its top edge is at least 50 mm above the adjacent platform level. A toe board on the access side is not permitted unless it is removable during access to and from the platform.			P															
	<p align="center">Table 4 — Dimensions of platform and toe board</p> <p align="right">Dimensions in millimetres</p> <table border="1"> <thead> <tr> <th></th> <th>a</th> <th>l₆</th> <th>l₇</th> <th>b</th> </tr> </thead> <tbody> <tr> <td>min.</td> <td>50</td> <td>400</td> <td>400</td> <td>0</td> </tr> <tr> <td>max.</td> <td></td> <td>1 000</td> <td>1 000</td> <td>≤ a</td> </tr> </tbody> </table> 		a	l ₆	l ₇	b	min.	50	400	400	0	max.		1 000	1 000	≤ a			P
	a	l ₆	l ₇	b															
min.	50	400	400	0															
max.		1 000	1 000	≤ a															
	a (Min. 50 mm)			P															
	l ₆ (Min. 400 mm; Max. 1 000 mm)			P															
	l ₇ (Min. 400 mm; Max. 1 000 mm)		700 mm	P															
	b (Min. 0 mm; Max. ≤ a)			P															
5.4	Working area			P															
	The working area is shown in Figure 9. The dimensional requirements are given in Table 5.			P															
	Distance between the guardrail and the top of the platform: w			P															
	Interior distance between the front guardrail and the gate: x		x=700 mm	P															
	Interior distance between the guardrails: y			P															
	Clear between the platform and the guardrail: z		z=0 mm	P															
	<p align="center">Table 5 — Dimensional requirements for the working area</p> <p align="right">Dimensions in millimetres</p> <table border="1"> <thead> <tr> <th></th> <th>w</th> <th>x</th> <th>y</th> <th>z</th> </tr> </thead> <tbody> <tr> <td>min.</td> <td>950</td> <td>400</td> <td>400</td> <td></td> </tr> <tr> <td>max.</td> <td>1100</td> <td></td> <td></td> <td>80</td> </tr> </tbody> </table> 		w	x	y	z	min.	950	400	400		max.	1100			80			P
	w	x	y	z															
min.	950	400	400																
max.	1100			80															

EN 131-7: 2013										
Clause	Requirement	Test	Result - Remark	Verdict						
5.5	Wheels and castors			P						
	The mobile ladder shall be fitted with devices which ensure that there is no movement of the mobile ladder while in position of use.		Contact points of the legs with the ground with slip resistant material.	P						
5.6	Prevention of falls: Guardrails, Middle rails			P						
	The height of the guardrail shall be at least 950 mm from the platform to the top of the guardrail.			P						
	The guardrails and middle rails shall avoid a sphere (470 mm diameter d) to pass (see Figure 10).			P						
	Ascending side(s) are optional to fit guard rails, middle rails and gates. They can be rigid or flexible such as chains, ropes etc. NOTE In some countries, it is compulsory to fit these elements.		Informative: fitted with gate in the ascending side.	-						
	Table 6 — Dimensional requirements for guardrail			P						
		Dimensions in millimetres								
		<table border="1"> <thead> <tr> <th></th> <th>w</th> </tr> </thead> <tbody> <tr> <td>min.</td> <td>950</td> </tr> <tr> <td>max.</td> <td>1 100</td> </tr> </tbody> </table>		w	min.	950	max.	1 100		
	w									
min.	950									
max.	1 100									
5.7	Handrails			P						
	Handrails shall be fitted on products when the angle α of the ascending legs is $\geq 45^\circ$ and $\leq 60^\circ$ as shown in the Figure 11.		The angle $\alpha=60^\circ$.	P						
6	TESTING			-						
6.1	General			-						
	All the tests shall be conducted in the most unfavourable position of the mobile ladder and its components			P						
6.2 (5.7 of EN 131-2)	Torsion test of steps, rungs, wide rungs			P						
	This test shall be according EN 131-2.			P						
(5.7 of EN 131-2)	Torsion test of rungs and steps			P						
	A torque M of 50 Nm (see Figure 17) shall be applied on the midpoint of the rung or step via a 100 mm wide clamping device. The torque shall be applied alternately 10 times in clockwise and 10 times in counter-clockwise direction for a period of 10 s each.			P						
	During testing there shall be no relative movement in the connection between stile and rung/step.			P						
	After the test a permanent deformation shall be 1° at maximum with a tolerance of $\pm 0,2^\circ$.			P						

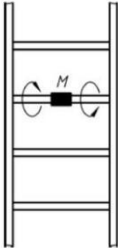
EN 131-7: 2013				
Clause	Requirement	Test	Result - Remark	Verdict
		 <p>Figure 17 — Torsion test of rungs and steps</p>		P
6.3 (5.3 & 5.6 of EN 131-2)	Bending test for steps, rungs, wide rungs			P
	This test shall be according EN 131-2.			P
(5.3 of EN 131-2)	<i>Bending</i> test of the stiles			P
	The test shall be carried out on the complete ladder.			P
	In the case of extending ladders and combination ladders the test shall be carried out on the complete extended ladder. Sectional ladders shall be tested at full length with all permitted pieces. The test shall be carried out without supporting legs if not permanently fixed to the ladder.			N/A
	Where the ascendable side cannot be determined by the construction of the product, or where it is a multiple part combination ladder the ladder shall be tested twice. For the second test the ladder shall be rotated 180° about the longitudinal axis.			N/A
	The ladder shall be placed horizontally on supports situated 200 mm from each end of the ladder.			P
	The supports shall be cylindrical with diameters between 25 mm and 100 mm and one shall be free to rotate the other shall be fixed.			P
	The test load shall be slowly applied in the middle of the ladder equally to both stiles over a width of 100 mm while it has to be taken care that an applying by jerks is avoided.			P
	A pre-load of 100 N shall be applied for the duration of one minute. The position of the ladder after removal of the pre-load is the origin for the measurement.			P
	A test load F of 750 N (see Figure 11) shall be applied vertically on the centre of the ladder for a duration of at least 1 min.			P

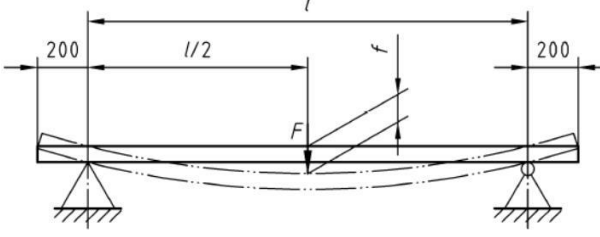
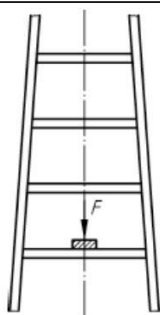
EN 131-7: 2013				
Clause	Requirement	Test	Result - Remark	Verdict
		 <p style="text-align: center;">Figure 11 — Bending test</p>		P
	Thereby the maximum permissible deflection f_{max} as a function of the distance l between the supports shall be:			-
	$f_{max} = 5 \times l^2 \times 10^{-6}$ mm for ladders of length less than or equal to 5 m;			P
	$f_{max} = 0,043 \times l - 90$ mm for ladders of length more than 5 m and less than or equal to 12 m;			N/A
	$f_{max} = 0,06 \times l - 294$ mm for ladders of length more than 12 m.			N/A
(5.6 of EN 131-2)	Vertical load on rungs, steps and platforms			-
5.6.1	General			-
	A pre-load F of 200 N shall be applied for the duration of one minute. The position of the rung/step/platform after removal of the pre-load is the origin for measurement.			P
5.6.2	Rungs and steps			
	In the position of use of the ladder a test load F of 2 600 N (see Figure 15) shall be applied vertically on the mid-point of the weakest rung or step of any design evenly distributed over a width of 100 mm and a depth equal to the rung/step and for the duration of one min.			P
		 <p style="text-align: center;">Figure 15 — Vertical load test on rungs/steps/platform</p>		P
	The maximum permanent deformation after removal of the test-load shall be less than or equal to 0,5 % of the inner width b_1 (see EN 131-1), measured underneath the tested step.			P

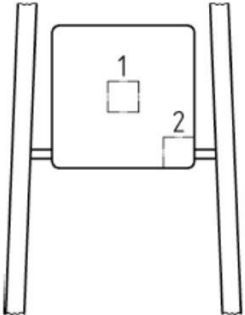
EN 131-7: 2013				
Clause	Requirement	Test	Result - Remark	Verdict
5.6.3	Platform			-
	The platform shall be tested at two positions, in the centre and at a corner of the front edge (see Figure 16).			P
				P
	Figure 16 — Positions of load			
	With the ladder positioned as in use, a test load F of 2 600 N, uniformly distributed over an area of 100 mm × 100 mm shall be applied for the duration of one min.			P
	The maximum permanent deformation after removal of each test load shall be less than or equal to 0,5 % of the inner width b1 (see EN 131-1), measured from above the platform parallel to the rungs or steps at the point where the load has been applied. The requirement after the second test shall be that no permanent deformation greater than 0,5 % of b1 is visible at the connection between platform and stile measured from the underside.			P
6.4	Platform and complete product test			P
6.4.1	Platform test			P
6.4.1.1	Test for all platform sizes			P
	The tests (see Figure 12) shall be carried out according to the testing procedure in EN 131-2, except the platform shall be tested at the following four positions:			P
	— in the middle of the platform;			P
	— in the middle of the front edge;			P
	— in the middle of the rear edge;			P
	— at one of the two front corners			P

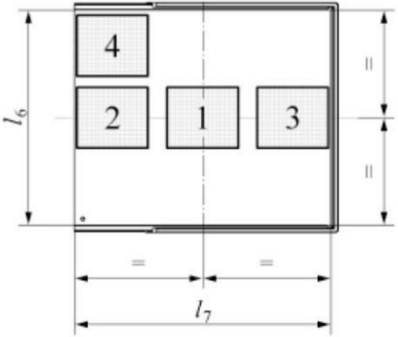
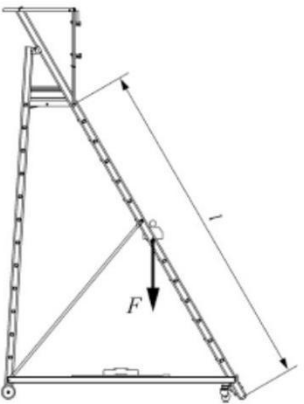
EN 131-7: 2013				
Clause	Requirement	Test	Result - Remark	Verdict
		 <p style="text-align: center;">Figure 12 — Platform test for platform area $\leq 0,5 \text{ m}^2$</p>	<p>Apply force 2600 N, 1 min.</p> <p>During and after test; no disassembly, cracking or rupture occurs.</p>	P
6.4.1.2	Platform Area $> 0,5 \text{ m}^2$		Not more than $0,5 \text{ m}^2$.	N/A
6.4.2	Complete product test			P
	The product is placed in the use position. The stability devices/ ballast shall be fitted in position.			P
	Place the test load $F = 3\,500 \text{ N}$ in the middle of the ascending leg uniformly distributed on the surface of the rung/wide rung/step for a period of 1 min (see Figure 14).			P
	Requirement: no disassembly, cracking or rupture shall occur			P
		 <p style="text-align: center;">Figure 14 — Complete product test</p>		P
6.5	Protection bending test			P
6.5.1	Tests on guardrails (principal guardrails and top handrail of the gate)			P
	To eliminate the free movements apply a preload of 20 N horizontally for a period of 1 min. The position of the handrail under the preload is the starting point for the measurement of bending.			P
	— Apply the test load of 300 N horizontally for one minute distributed over a length of 100 mm and a depth equal to the principal guardrail in the most unfavourable position and direction, and then measure the deflection.			P

EN 131-7: 2013				
Clause	Requirement	Test	Result - Remark	Verdict
	Requirement: maximum deflection under load 35 mm.			P
	— Apply the test load of 1 250 N vertically for one minute distributed over a length of 100 mm and a width equal to the principal guardrail in the most unfavourable position, and then pull the load off.			P
	Requirement: no disassembly, cracking or rupture shall occur.			P
6.5.2	Test on middle rail (intermediate guardrail and the middle rail of the gate)			P
	Apply the test load of 1 250 N vertically for 1 min, than put the load off.			P
	Requirement: no disassembly, cracking or rupture shall occur.			P
6.6	Side handrail testing			P
	This test shall be according to EN 131-2.			P
6.7	Stability test			P
6.7.1	Platform $\leq 0,5 \text{ m}^2$			P
	Place the mobile platform ladder in position of use, complete with any ballast and/or stabilisers, with any brake device activated on an even and solid ground. The castors shall be placed in the most unfavourable position.			P
	Apply a test load of 750 N distributed centred on a rigid steel plate of max. 200 mm × 200 mm located on the centre of the platform.			P
	Apply a suitable system to prevent slippage of the ladder towards the direction of the horizontal force. This system shall not change the resistance to overturning of the mobile platform ladder and shall have a height above the ground not greater than 10 mm.			P
	Apply gradually to the level of the platform a horizontal pulling force $F = 300 \text{ N}$ to the edge of the platform in the most unfavourable position and direction (see Figures 15 and 16).		Tested 19408EN-146.	P
	For platform heights greater than 2,5 m, the pulling force is increased to $F = 450 \text{ N}$ when the product is intended for outdoor use or where it might be affected by wind.		Tested 19410EN-146.	P

EN 131-7: 2013

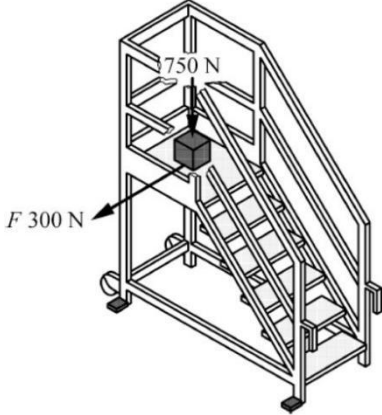
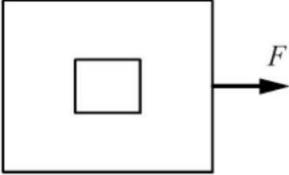
Clause	Requirement Test	Result - Remark	Verdict
	<p>The test is passed if the mobile platform ladder does not overturn.</p>  <p>Figure 15 – Stability test</p>	Does not overturn.	P
	 <p>Figure 16 – Diagram of the platform</p>		P
6.7.2	Platform > 0,5 m ²	Not more than 0,5 m ² .	N/A
6.8	Stiffness test		P
	Place the mobile platform ladder in position of use, complete with any ballast and/or stabilisers, with any brake device activated on an even and solid ground. The castors shall be placed in the most unfavourable position.		P
	To establish the origin for measurement, apply a pre load of 20 N horizontally over a period of 1 min		P
	Apply a test load of 750 N distributed centred over a rigid steel plate of max. 200 mm × 200 mm in the middle of the platform.		P
	Apply a suitable system to prevent losing contact of all feet/wheels to the ground without affecting the original stiffness of the mobile platform ladder.		P
	Apply gradually to the level of the platform a horizontal pulling load of 300 N at the edge of the platform in the most unfavourable position and direction (see Figure 19 and Figure 20).		P

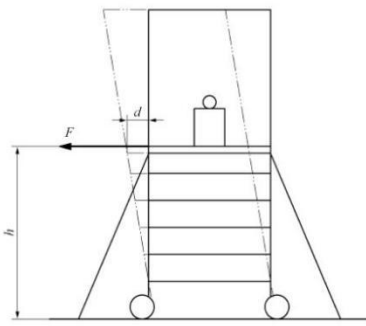
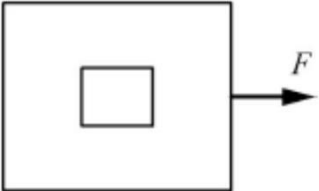
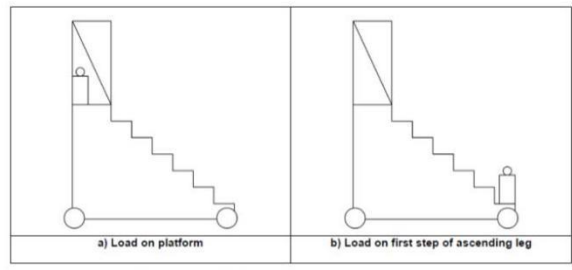
EN 131-7: 2013				
Clause	Requirement	Test	Result - Remark	Verdict
	<p>The maximum deflection d measured under load at platform height is: $d \leq 10 \text{ mm} + 0,01 \times h$.</p> 		<p>Tested 19408EN-146 and 19410EN-146.</p>	P
	 <p>Figure 20 – Diagram of the platform</p>			P
6.9	Test for products equipped with spring wheels		No such spring wheels.	N/A
	Apply a test load of 200 N uniformly distributed over a rigid steel plate of 100 mm x 100 mm on the centre of the first step of the ascending leg (see Figure 21 b)). This test shall be repeated for every other ascending leg.			N/A
	When the product has only one ascending leg, the test is also carried out with the test load on the centre of the edge of the platform (see Figure 21a)).			N/A
	Requirement: both feet of the side where the load is applied shall be in contact with the floor during the test.			N/A
	 <p>Figure 21 – Test for products equipped with spring wheels</p>			N/A
6.10 (5.10 of EN 131-2)	Kick-up test of the platform			P
	This test shall be carried out in accordance with EN 131-2.			P
(5.10 of EN 131-2)	<i>Kick-up test of the platform of standing ladders</i>			P

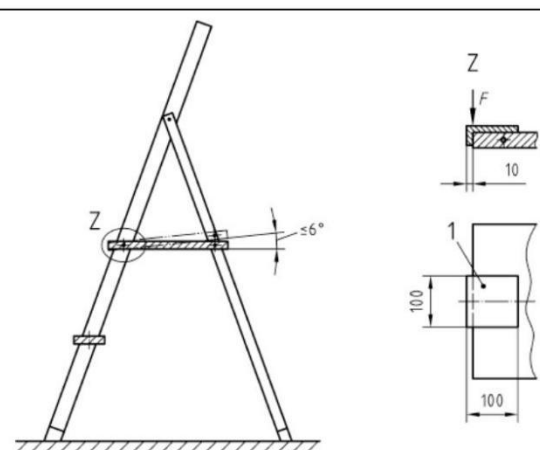
EN 131-7: 2013				
Clause	Requirement	Test	Result - Remark	Verdict
		Place the standing ladder in the working position on a level surface and apply a force F of 100 N over a 100 mm width to the pivoted edge of the platform at an angle of 90° to the horizontal towards the vertical centre line of the steps (see Figure 20). The platform shall not lift from its stop by more than 6°.		P
		 <p>Figure 20 — Kick-up test of the platform of standing step ladders</p>		P
6.11 (5.8 of EN 131-2)	Test of opening restraint devices			P
	The product shall be tested in position of use according to EN 131-2. The products shall be tested with all points normally in contact with the ground supported on rollers (refer to EN 131-2 for specifications on rollers).			P
(5.8 of EN 131-2)	Test of opening restraints and hinges of standing ladders			P
5.8.1	General This test is for standing ladders or combination ladders used as standing ladders. For the purpose of this test, the working position for these ladders is two parts connected at the top and secured against sliding away from each other. Where a ladder is fitted with both automatic and manual restraint devices, only the automatic device shall be employed. The engagement of a ladders manual restraint device is only permitted where no automatic device is fitted.			P
	Each leg of the ladder in the working position is placed on a platform provided with multidirectional rollers (see Figure 18). The effects of friction, from both the rollers and floor surface, shall be negligible. The test is to be conducted on a clean, smooth finish concrete floor.			P

EN 131-7: 2013				
Clause	Requirement	Test	Result - Remark	Verdict
		After removal of the test loads of the tests according to 5.8.2 to 5.8.4 no visible permanent deformation shall occur on the hinge joints, opening restraint devices and their attachments. The ladder shall not show any visible damages such as cracks, indentations, etc. Permanent deformation is acceptable only if it does not impair the fitness for use of the ladder	No any visible damages such as cracks, indentations, etc. No permanent deformation.	P
		 <p>Figure 18 — Test of opening restraint devices and hinges of standing ladders</p>		P
5.8.2	Bilaterally ascendable ladder		Not bilaterally ascendable ladders.	N/A
		The test load F of 2 600 N is divided into two loads of 1 300 N (see Figure 18), distributed over two plates each 100 mm long with a width at least equal to the surface of the rung or step to be applied to the uppermost rung or step as close as possible to the stiles for a duration of 1 min. This test is then repeated on the other leg.		N/A
5.8.3	Standing ladder with platform			P
		The test load F of 2 600 N is divided into two loads of 1 300 N, distributed over two plates that are each 100 mm × 100 mm to be applied to front edge of the platform as close as possible to the stiles for a duration of 1 min. This test is then repeated on the rear edge of the platform.		P
5.8.4	Unilaterally ascendable ladder			P
		The test load F of 2 600 N is divided into two loads of 1 300 N, distributed over two plates each 100 mm long with a width at least equal to the surface of the rung or step to be applied to the uppermost rung or step of the ascending leg as close as possible to the stiles for a duration of 1 min.		P
6.12 (5.9 of EN 131-2)	Test of hooks			N/A

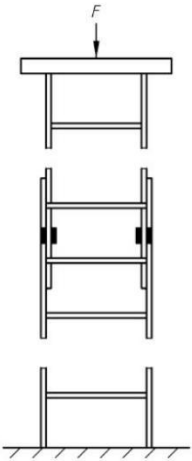
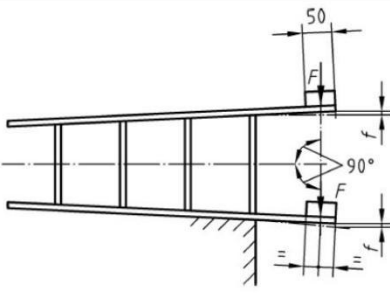
EN 131-7: 2013				
Clause	Requirement	Test	Result - Remark	Verdict
	Mobile platform ladders, which can be extended, shall be tested in according to EN 131-2.		Can't be extended.	N/A
(5.9 of EN 131-2)	Test for ladder rung/step hooks of extending ladders and combination ladders		Not such ladders.	N/A
	The ladder is extended by at least one rung/step distance and placed in a vertical position. The length of the test piece will be left to the choice of the tester. A uniformly distributed test load F of 3 500 N (see Figure 19) shall be applied vertically to the upper part of the ladder for a period of 1 min. After removal of the test load, there shall be no permanent deformation which impairs the fitness for use of the ladder.			N/A
		 <p>Figure 19 — Test for locking devices</p>		N/A
6.13 (5.5 of EN 131-2)	Bottom stile end test This test is according to EN 131-2.			P
(5.5 of EN 131-2)	Bottom stile ends test			P
	Place the ladder laterally, with the longitudinal axis of the ladder in the horizontal position. The lower stile is to be fixed to the support so that the stile ends overhang the supporting surface (see Figure 13).			P
		 <p>Figure 13 — Test method of the bottom stile ends</p>		P

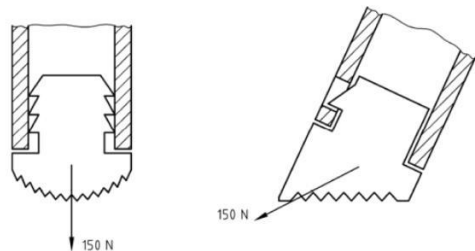
EN 131-7: 2013				
Clause	Requirement	Test	Result - Remark	Verdict
		If the rungs/steps are bolted, riveted, or similarly fixed to the stile the edge of the support shall be in line with the bottom lower edge of the assembling hole.		P
		If the rungs/steps are fixed to the stile without the stile being penetrated the edge of the support shall be in line with the lower edge of the rung/step.		N/A
		If the ladder has a bar type stabilizer then this test is not carried out.		N/A
		A rigid load block 50 mm wide is placed with its end up to and parallel with the end of the stile. The load block shall rest on the stile and shall effect the whole width of the stile. The lateral deflection f of the stile end is measured at the outer edge of the load block in the longitudinal axis.		P
		A vertical force F of 1 100 N (see Figure 13 and 14) is placed in the middle of the load block and is maintained for one min. The permanent deflection after removal of the test load together with any damages are noted.		P
		The test is repeated on the lower stile without turning the ladder.		P
		Requirement: The permanent deflection f in each test shall not exceed 2 mm.		P
		Neither fracture nor visible cracks are allowed.		P
		This test shall also be performed on supporting legs.		P
6.14 (5.11 of EN 131-2)		Feet pull test		P
		This test is according to EN 131-2.		P
(5.11 of EN 131-2)		Feet pull test		P
5.11.1		For ladder feet made of one part		-
		Fix the ladder. Attach a fixing to the centre of a ladder foot.		P
		The force is to be applied in a direction most likely to separate the foot from the stile. A load of 150 N shall be applied for 1 min (examples are given in Figure 21).		P
		 <p>Figure 21 — Testing of the ladder feet which are fixed to the ladder</p>		P

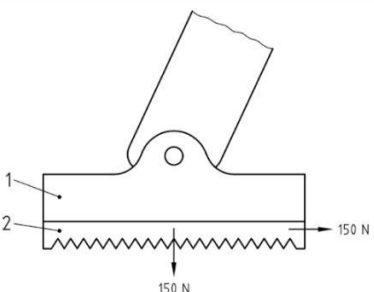
EN 131-7: 2013				
Clause	Requirement	Test	Result - Remark	Verdict
		After the test, the foot shall remain functional and show a separation from the stile of less than or equal to 4 mm.	No any separation.	P
5.11.2		For feet made of one part on stabilizer bars supplied by the ladder manufacturer		N/A
		Prevent the ladder from moving by placing stops around one pair of feet.		N/A
		Apply the force to a free foot in the position and direction most likely to separate the foot from the stabilizer bar. A load of 150 N shall be applied for 1 min (see Figure 22).		N/A
		After the test, the foot shall remain functional and show a movement from its original position of less than or equal to 4 mm.		N/A
5.11.3		For ladder feet and feet of stabilizer bars made of more than one part		N/A
		The relevant test in 5.11.1 or 5.11.2 shall be performed. Additionally, the section of the foot that generates resistance to movement relative to the ground shall have a load of 150 N applied for 1 min in a location and direction that is likely to be the most critical, as determined by the tester (see Figure 23). After the test, there shall be no indication of separation between the different parts of the foot.		N/A
		 <p>Key 1 upper part 2 lower part</p> <p>Figure 23 — Testing of ladder feet made of more than one part</p>		N/A
		If the sections of the ladder foot that provide the friction between the ladder and the ground are loosened or lost, this shall be clearly visible when the ladder is in the position of use. When these sections are worn through, this shall also be visible during the pre-use inspection of the ladder.		N/A
		The sections of the ladder foot that are designed to provide the friction between the ladder and the ground shall be the only part of the foot in contact with the ground under user or test load with in the position of use. This part of the ladder foot, even when worn, shall not be capable of being pushed inside the upper part of the foot when the ladder is in the position of use.		N/A

EN 131-7: 2013				
Clause	Requirement	Test	Result - Remark	Verdict
6.15 (5.16 of EN 131-2)	Test method for plastic ladders			N/A
	This test is according to EN 131-2.			N/A
5.16	Test methods for plastic ladders			-
5.16.1	Thermoset plastics and composite materials			-
5.16.1.1	Principle			-
	In order to determine the utilisation characteristics of composite materials in the load-bearing elements (e. g. stiles, rungs, steps, platforms) of the structure of ladders, tests shall be carried out according to two test series as preferred: a) The first test series of two batches of 10 samples shall be subjected to the shock test (EN ISO 179-1) without undergoing the ageing test for the first batch and after the ageing test (EN ISO 4892-2) for the second batch; b) a second series of specimens comprising 2 batches of 5 samples shall be subjected to the bending test (EN ISO 14125) without undergoing the ageing test for the first batch and after the ageing test (EN ISO 4892-2) for the second batch.			N/T
5.16.1.2	Preparation of the samples			-
	The specimens for the ageing test shall be taken from profile of the thinnest thickness scheduled. The specimens shall be sampled according to the main fibre direction(s) into load-bearing elements of the finished product by the test laboratory.			-
5.16.1.3	Ageing test			-
	One batch from each series of specimens shall be subjected to the ageing test according to the method of EN ISO 4892-2 under the following test conditions: - the test duration shall be: 500 h; - the specimens shall be exposed to a xenon arc light source according to method A and in compliance with Table 1 of EN ISO 4892-2:2006; - the reference temperature chosen for the black standard is (65 ± 3) °C; - the relative humidity chosen is (65 ± 3) %; - the cycle shall be conducted without any dark period under continuous illumination for (102 ± 0,5) min and a sprinkling period of (18 ± 0,5) min; - the test shall not form the subject of EN ISO 4892-2 concerning the determination of post-exposure property changes.			N/T
5.16.1.4	Shock test			-

EN 131-7: 2013													
Clause	Requirement	Test	Result - Remark	Verdict									
	The shock test shall be conducted on the two batches of 10 specimens of the first series (see 5.16.1.1) according to EN ISO 179-1 under the following conditions: - the shocks shall be administered perpendicular to the longitudinal direction of the fibres; - the shocks shall be delivered in flat position (f) and in normal position (n).			N/T									
5.16.1.5	Bending test			-									
	The bending test shall be carried out on the two batches of 5 samples of the second series (see 5.16.1.1) according to EN ISO 14125 under the following conditions.			N/T									
	The bending properties determination test shall be conducted in accordance with the 3 point loading method (method A — Class IV).			N/T									
5.16.1.6	Acceptance criteria			-									
	Acceptance criteria for the difference before and after the ageing test are defined in Table 4: Table 3 — Acceptance criteria for composite materials			N/T									
	<table border="1"> <thead> <tr> <th>Test type</th> <th>Standard</th> <th>Acceptance criterion</th> </tr> </thead> <tbody> <tr> <td>Shock</td> <td>EN ISO 179-1</td> <td>≤ 20 %</td> </tr> <tr> <td>Bending</td> <td>EN ISO 14125</td> <td>≤ 20 %</td> </tr> </tbody> </table>	Test type	Standard	Acceptance criterion	Shock	EN ISO 179-1	≤ 20 %	Bending	EN ISO 14125	≤ 20 %			N/T
Test type	Standard	Acceptance criterion											
Shock	EN ISO 179-1	≤ 20 %											
Bending	EN ISO 14125	≤ 20 %											
5.16.2	Reinforced thermoplastics			N/A									
5.16.2.1	Principle			N/A									
	In order to determine the utilisation characteristics of the plastic materials in the load-bearing elements of the structure of ladders, tests shall be carried out in the following sequence: a) a first test series of two batches of five specimens shall be subjected to the tensile test (EN ISO 527-1 and EN ISO 527-2), but before the ageing test for the first batch and after the ageing test (EN ISO 4892-2) for the second batch, b) a second test series is conducted on three finished products in a chamber under cold (– 20 °C) and hot (60 °C) conditions.			N/A									
5.16.2.2	Specimen testing			N/A									
	a) Preparation of specimens			N/A									
	The specimens for the ageing and tensile tests shall be sampled from the different elements of the ladder structure.			N/A									
	b) Ageing test			N/A									

EN 131-7: 2013				
Clause	Requirement	Test	Result - Remark	Verdict
	A batch of the first test series of specimens shall be subjected to the ageing test according to the method of EN ISO 4892-2 under the following test conditions:			N/A
	1) the test duration shall be 500 h;			
	2) the specimens shall be exposed to a xenon arc light source according to method A and in compliance with Table 4;			
	3) the reference temperature chosen for the black standard is $(65 \pm 3) ^\circ\text{C}$;			
	4) the relative humidity chosen is $(65 \pm 5) \%$;			
	5) the cycle shall be conducted without any dark period under continuous illumination for $(102 \pm 0,5)$ min and a sprinkling period of $(18 \pm 0,5)$ min;			
	6) the test shall not form the subject of EN ISO 4892-2 concerning the determination of post-exposure property changes.			
	c) Tensile test			N/A
	The tensile test shall be conducted on the two batches of five specimens of the first series (see 5.16.2.1) according to EN ISO 527-1 and EN ISO 527-2.			N/A
5.16.2.3	Acceptance criteria			N/A
	The acceptance criteria before and after the ageing test shall be $\leq 20 \%$ of the results obtained at the time of the tensile test. If the test results on the specimen samples are positive, tests should be carried out on three finished products successively under cold ($-20 ^\circ\text{C}$) and hot ($60 ^\circ\text{C}$) conditions.			N/A
	a) Cold testing			N/A
	The three finished products are placed in a chamber at $(-20 \pm 1) ^\circ\text{C}$ during 24 h. After temperature stabilisation at $-20 ^\circ\text{C}$, the finished products are submitted to testing: For ladders, conduct tests 5.2 Ladder strength test, 5.3 Ladder bending test and 5.6 strength test of rungs/steps/ platforms.			N/A
	If the tests meet the given acceptance criteria, the same finished products are subjected to hot testing.			N/A
	b) Hot testing			N/A
	The three finished products submitted to cold testing are stored at room temperature for 24 h, then placed in a chamber at $(60 \pm 1) ^\circ\text{C}$ for 24 h. After temperature stabilisation at $(60 \pm 1) ^\circ\text{C}$, the finished products are subjected to the same tests described for cold testing.			N/A
5.16.3	Dielectric test			-

EN 131-7: 2013				
Clause	Requirement	Test	Result - Remark	Verdict
5.16.3.1	General			-
	The dielectric test applies for the suitability of ladders for a use where the voltage is less than 1 000 V a.c and 1 500 V d.c. The tests shall be mandatory for all ladders declared as insulated. When ladders are used where the electrical voltage is greater than 1 000 V, then the ladders shall comply with EN 61478.			N/T
5.16.3.2	Preparation of the test piece			-
	The test piece is taken from the ladder and shall include at least two adjacent rungs. In the case of spliced ladder, the test piece shall include the part with the connecting device (most sensitive part of the ladder). The dielectric test is carried out on the insulation material sections, which have undergone a mechanical ageing test as described in 5.16.1.3.			N/T
5.16.3.3	Procedure	The section is immersed for 24 h in water with a resistivity of $(100 \pm 15) \Omega \times m$. The ladder is then removed from the water bath and hung upright for 4 h. Prior to applying the test voltage the ladder is wiped carefully. Suitable electrodes, at least 50 mm in width, are attached to two successive rungs. These are positioned so as to ensure that the test voltage is applied to the stiles (see Figure 29).		N/T
	The voltage applied between adjacent electrodes is an alternative voltage with a frequency between 40 Hz and 62 Hz, increasing gradually from 0 to U_m , at the rate of 1 kV/s. The test voltage U_m is defined according to the spacing d between the 2 rungs by the equation: $U_m = 1\,000 \times d/300$			N/T
	The U_m voltage is applied for 1 min. The test is carried out on the adjacent rungs and in contact with the stiles (rails); The test is considered as passed if no flashover, no puncture and no temperature rise ($\Delta 5 \text{ }^\circ\text{C}$) occurs on the stiles.			N/T
(5.17 of EN 131-2)	Durability test for standing ladders			-
	10 000 cycles for non-professional class and 50 000 cycles for professional class			N/T
6.16	Marking durability			P
	This test shall be according to EN 131-2.			P
	Marking shall be durable. The durability of the marking shall be checked by inspection and by rubbing the marking lightly, first for 15 s with a cloth soaked in water and then for 15 s with a cloth soaked in petroleum spirit. There shall be no reduction in legibility at the conclusion of the test. Adhesive labels, where used, shall not have worked loose or become curled at the edges.			P
7	Marking, User and safety instruction			P
7.1	Marking			P

EN 131-7: 2013				
Clause	Requirement	Test	Result - Remark	Verdict
	Markings shall be displayed as specified in EN 131-3 and additionally the following specific markings when required:			P
	– comply with EN 131-7;			P
	– use only with stabiliser;			P
	– use only with ballast;			N/A
	– for outdoor use caution to the wind;			P
	– use only with activated brakes;			N/A
	– for platform heights greater than 2,5 m, a marking shall show if a product cannot be used outside. (Outdoor use is allowed if the product passes the required stability test described in 6.7.);		The product passes the required stability test described in 6.7.	N/A
	– for further markings specific for mobile ladders with platform			P
7.2	User Instruction			P
	User instructions shall be provided as specified in EN 131-3 and additionally the following specific safety instructions when required:			P
	– use only with stabiliser;			P
	– use only with ballast;			N/A
	– for outdoor use caution to the wind;			P
	– use only with activated brakes;			N/A
	– for platform heights greater than 2,5 m, the safety instructions shall specify if a product cannot be used outside (Outdoor use is allowed if the product passes the required stability test described in 6.7.);		The product passes the required stability test described in 6.7.	N/A
	– for further user instructions specific for mobile ladders with platform.			P
EN 131-3:2018				
4 (EN 131-3)	Provision of safety marking and user instructions			P
	The producer shall be responsible for the content of the safety marking and user instructions and the provision of the instructions for each ladder. The safety marking and user instructions shall be in the language of the country where the ladder is originally placed on the market.			P
	The user instruction shall indicate that it shall be read before using the ladder.			P
5 (EN 131-3)	Reasons for accidents			-

EN 131-7: 2013				
Clause	Requirement	Test	Result - Remark	Verdict
	a) loss of stability; b) from handling; c) slip, trip and fall of user; d) structural failure of ladder; e) electrical hazards			P
6 (EN 131-3)	Marking and user instruction			P
6.1	General			P
	All marking detailed under Clause 6 shall be fixed permanently, according to EN 131-2, to the ladder surface.			P
	In 6.3, the minimum requirements for marking and user instructions are specified.			P
	The user instruction shall list the items to be inspected and checked. The minimum list of items is shown in Annex A.			P
	Details of how to obtain the pass/fail criteria shall be in the user instructions or marked on the ladder;			P
	The user instruction shall be supplied with the ladder and should be made available on the producer's website also.			N/T
	The user instruction shall include identity and address of the producer and/or distributor including website address.			P
	User instructions shall repeat all safety markings which are on the ladder.			P
	The maximum number of safety signs should be reduced to a number that users are able to identify and comply with when using the ladder.			P
6.2	Basic marking on the ladder			P

EN 131-7: 2013				
Clause	Requirement	Test	Result - Remark	Verdict
	asic marking information may be given in the form of safety signs or text. The marking shall include: a) identity and address of the producer and/or distributor including website address for information about the ladder; b) type of ladder and possible modes of use; c) classification of use —professionalll or —non-professionalll as specified in EN 131-2; d) number of the general standard EN 131 or if a dedicated standard exists; e) month and year of production and/or serial number (may also be stamped); f) weight of the ladder (in kg) and maximal total load (in kg); g) insulation, if any. Information a), b), c) and f) shall also appear on the packaging or be otherwise clearly visible to the consumer before the purchase.			P
6.3	Safety marking and user instructions			P
6.3.1	General			P
	The basic safety marking shall be attached to all ladders and ladder parts which can be used separately as an easily viewed symbol.			P
	The marking to indicate the top most rung/step that shall be used for standing on, shall be placed: — on the stile of the ladder adjacent to or on the last /allowed; or — on the first /not allowed rung/step; or — on the label for safety marking.		On the label for safety marking.	P
	The user instructions shall be written in the official languages of the country where the ladder is placed on the market.			P
	The minimum size of text in the user instruction is 9 PT.			N/T
6.3.2	Safety signs			P
6.3.2.1	Basic safety signs			P
	The geometric shape of basic safety signs shall be in accordance with ISO 3864-1, ISO 3864-3 and be based upon the EN ISO 7010 template for safety signs with a minimum size d and h of 15 mm (see Figure 1).			P

EN 131-7: 2013

Clause	Requirement	Test	Result - Remark	Verdict
--------	-------------	------	-----------------	---------

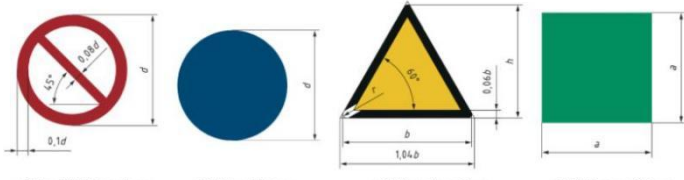
	 <p>a) Prohibition sign b) Mandatory action sign c) Warning sign d) Safe condition sign</p> <p align="center">Figure 1 — Basic safety signs according to ISO 3864-1</p>			P
--	--	--	--	---













6.3.2.2	Supplementary safety information symbols			P
---------	--	--	--	---

	–Necessary is indicated by a green tick and –Not allowed is indicated by a red X (see examples in Figure 2).			P
--	--	--	--	---































	The minimum height h of supplementary safety information symbols is 15 mm.			P
--	--	--	--	---

6.3.3	Basic safety marking and user instructions for all ladders			P
-------	--	--	--	---















	Table 1 shows the minimum requirements for safety marking, user instructions and the mandatory symbols for all ladders.			P
--	---	--	--	---

	<p align="center">Table 1 — Minimum basic requirements for safety marking and user instructions for all ladders</p> <table border="1"> <thead> <tr> <th>No.</th> <th>Item / Text</th> <th>Safety marking (Symbol)</th> <th>User instruction (Text or text and symbol)</th> <th>Symbol</th> </tr> </thead> <tbody> <tr> <td>1</td> <td>Warning, fall from the ladder. This warning sign shall appear on each marking on the ladder at the first place.</td> <td align="center">X</td> <td align="center">X</td> <td align="center">  EN ISO 7010-W008 </td> </tr> <tr> <td>2</td> <td>Refer to instruction manual/booklet</td> <td align="center">X</td> <td align="center">X</td> <td align="center">  EN ISO 7010-M002 </td> </tr> <tr> <td>3</td> <td>Inspect the ladder after delivery. Before every use visually check the ladder is not damaged and is safe to use. Do not use a damaged ladder.</td> <td align="center">X</td> <td align="center">X</td> <td align="center">  </td> </tr> <tr> <td>4</td> <td>Maximum total load</td> <td align="center">X</td> <td align="center">X</td> <td align="center">  </td> </tr> </tbody> </table>	No.	Item / Text	Safety marking (Symbol)	User instruction (Text or text and symbol)	Symbol	1	Warning, fall from the ladder. This warning sign shall appear on each marking on the ladder at the first place.	X	X	 EN ISO 7010-W008	2	Refer to instruction manual/booklet	X	X	 EN ISO 7010-M002	3	Inspect the ladder after delivery. Before every use visually check the ladder is not damaged and is safe to use. Do not use a damaged ladder.	X	X		4	Maximum total load	X	X				P
No.	Item / Text	Safety marking (Symbol)	User instruction (Text or text and symbol)	Symbol																									
1	Warning, fall from the ladder. This warning sign shall appear on each marking on the ladder at the first place.	X	X	 EN ISO 7010-W008																									
2	Refer to instruction manual/booklet	X	X	 EN ISO 7010-M002																									
3	Inspect the ladder after delivery. Before every use visually check the ladder is not damaged and is safe to use. Do not use a damaged ladder.	X	X																										
4	Maximum total load	X	X																										



















EN 131-7: 2013

Clause	Requirement	Test	Result - Remark			Verdict																																		
	<table border="1"> <thead> <tr> <th>No.</th> <th>Item / Text</th> <th>Safety marking (Symbol)</th> <th>User instruction (Text or text and symbol)</th> <th>Symbol</th> </tr> </thead> <tbody> <tr> <td>5</td> <td>Do not use the ladder on a unlevel or unfirm base.</td> <td align="center">X</td> <td align="center">X</td> <td></td> </tr> <tr> <td>6</td> <td>Do not overreach.</td> <td align="center">X</td> <td align="center">X</td> <td></td> </tr> <tr> <td>7</td> <td>Do not erect ladder on contaminated ground.</td> <td></td> <td align="center">X</td> <td></td> </tr> <tr> <td>8</td> <td>Maximum number of users</td> <td align="center">X</td> <td align="center">X</td> <td></td> </tr> <tr> <td>9</td> <td>Do not ascend or descend unless you are facing the ladder.</td> <td></td> <td align="center">X</td> <td></td> </tr> </tbody> </table>	No.	Item / Text	Safety marking (Symbol)	User instruction (Text or text and symbol)	Symbol	5	Do not use the ladder on a unlevel or unfirm base.	X	X		6	Do not overreach.	X	X		7	Do not erect ladder on contaminated ground.		X		8	Maximum number of users	X	X		9	Do not ascend or descend unless you are facing the ladder.		X					P					
No.	Item / Text	Safety marking (Symbol)	User instruction (Text or text and symbol)	Symbol																																				
5	Do not use the ladder on a unlevel or unfirm base.	X	X																																					
6	Do not overreach.	X	X																																					
7	Do not erect ladder on contaminated ground.		X																																					
8	Maximum number of users	X	X																																					
9	Do not ascend or descend unless you are facing the ladder.		X																																					
	<table border="1"> <thead> <tr> <th>No.</th> <th>Item / Text</th> <th>Safety marking (Symbol)</th> <th>User instruction (Text or text and symbol)</th> <th>Symbol</th> </tr> </thead> <tbody> <tr> <td>10</td> <td>Keep a secure grip on the ladder when ascending and descending. Maintain a handhold whilst working from a ladder or take additional safety precautions if you cannot.</td> <td></td> <td align="center">X</td> <td></td> </tr> <tr> <td>11</td> <td>Avoid work that imposes a sideways load on ladders, such as side-on drilling through solid materials.</td> <td></td> <td align="center">X</td> <td></td> </tr> <tr> <td>12</td> <td>Do not carry equipment which is heavy or difficult to handle while using a ladder.</td> <td></td> <td align="center">X</td> <td></td> </tr> <tr> <td>13</td> <td>Do not wear unsuitable footwear when climbing a ladder.</td> <td></td> <td align="center">X</td> <td></td> </tr> <tr> <td>14</td> <td>Do not use the ladder if you are not fit enough. Certain medical conditions or medication, alcohol or drug abuse could make ladder use unsafe.</td> <td></td> <td align="center">X</td> <td></td> </tr> <tr> <td>15</td> <td>Do not spend long periods on a ladder without regular breaks (tiredness is a risk).</td> <td></td> <td align="center">X</td> <td align="center">-</td> </tr> </tbody> </table>	No.	Item / Text	Safety marking (Symbol)	User instruction (Text or text and symbol)	Symbol	10	Keep a secure grip on the ladder when ascending and descending. Maintain a handhold whilst working from a ladder or take additional safety precautions if you cannot.		X		11	Avoid work that imposes a sideways load on ladders, such as side-on drilling through solid materials.		X		12	Do not carry equipment which is heavy or difficult to handle while using a ladder.		X		13	Do not wear unsuitable footwear when climbing a ladder.		X		14	Do not use the ladder if you are not fit enough. Certain medical conditions or medication, alcohol or drug abuse could make ladder use unsafe.		X		15	Do not spend long periods on a ladder without regular breaks (tiredness is a risk).		X	-				P
No.	Item / Text	Safety marking (Symbol)	User instruction (Text or text and symbol)	Symbol																																				
10	Keep a secure grip on the ladder when ascending and descending. Maintain a handhold whilst working from a ladder or take additional safety precautions if you cannot.		X																																					
11	Avoid work that imposes a sideways load on ladders, such as side-on drilling through solid materials.		X																																					
12	Do not carry equipment which is heavy or difficult to handle while using a ladder.		X																																					
13	Do not wear unsuitable footwear when climbing a ladder.		X																																					
14	Do not use the ladder if you are not fit enough. Certain medical conditions or medication, alcohol or drug abuse could make ladder use unsafe.		X																																					
15	Do not spend long periods on a ladder without regular breaks (tiredness is a risk).		X	-																																				













EN 131-7: 2013

Clause	Requirement	Test	Result - Remark		Verdict																																													
	<table border="1"> <thead> <tr> <th>No.</th> <th>Item / Text</th> <th>Safety marking (Symbol)</th> <th>User instruction (Text or text and symbol)</th> <th>Symbol</th> </tr> </thead> <tbody> <tr> <td>16</td> <td>Prevent damage of the ladder when transporting e.g. by fastening and, ensure they are suitably placed to prevent damage.</td> <td></td> <td>X</td> <td>-</td> </tr> <tr> <td>17</td> <td>Ensure the ladder is suitable for the task.</td> <td></td> <td>X</td> <td>-</td> </tr> <tr> <td>18</td> <td>Do not use the ladder if contaminated, e.g. with wet paint, mud, oil or snow.</td> <td></td> <td>X</td> <td>-</td> </tr> <tr> <td>19</td> <td>Do not use the ladder outside in adverse weather conditions, such as strong wind.</td> <td></td> <td>X</td> <td>-</td> </tr> <tr> <td>20</td> <td>For professional use a risk assessment shall be carried out respecting the legislation in the country of use.</td> <td></td> <td>X</td> <td>-</td> </tr> <tr> <td>21</td> <td>When positioning the ladder take into account risk of collision with the ladder e.g. from pedestrians, vehicles or doors. Secure doors (not fire exits) and windows where possible in the work area.</td> <td></td> <td>X</td> <td>-</td> </tr> <tr> <td>22</td> <td>Warning, electricity hazard Identify any electrical risks in the work area, such as overhead lines or other exposed electrical equipment and do not use the ladder where electrical risks occur.</td> <td></td> <td>X X</td> <td>  </td> </tr> <tr> <td>23</td> <td>Use non-conductive ladders for unavoidable live electrical work.</td> <td></td> <td>X</td> <td>-</td> </tr> </tbody> </table>	No.	Item / Text	Safety marking (Symbol)	User instruction (Text or text and symbol)	Symbol	16	Prevent damage of the ladder when transporting e.g. by fastening and, ensure they are suitably placed to prevent damage.		X	-	17	Ensure the ladder is suitable for the task.		X	-	18	Do not use the ladder if contaminated, e.g. with wet paint, mud, oil or snow.		X	-	19	Do not use the ladder outside in adverse weather conditions, such as strong wind.		X	-	20	For professional use a risk assessment shall be carried out respecting the legislation in the country of use.		X	-	21	When positioning the ladder take into account risk of collision with the ladder e.g. from pedestrians, vehicles or doors. Secure doors (not fire exits) and windows where possible in the work area.		X	-	22	Warning, electricity hazard Identify any electrical risks in the work area, such as overhead lines or other exposed electrical equipment and do not use the ladder where electrical risks occur.		X X		23	Use non-conductive ladders for unavoidable live electrical work.		X	-				P
No.	Item / Text	Safety marking (Symbol)	User instruction (Text or text and symbol)	Symbol																																														
16	Prevent damage of the ladder when transporting e.g. by fastening and, ensure they are suitably placed to prevent damage.		X	-																																														
17	Ensure the ladder is suitable for the task.		X	-																																														
18	Do not use the ladder if contaminated, e.g. with wet paint, mud, oil or snow.		X	-																																														
19	Do not use the ladder outside in adverse weather conditions, such as strong wind.		X	-																																														
20	For professional use a risk assessment shall be carried out respecting the legislation in the country of use.		X	-																																														
21	When positioning the ladder take into account risk of collision with the ladder e.g. from pedestrians, vehicles or doors. Secure doors (not fire exits) and windows where possible in the work area.		X	-																																														
22	Warning, electricity hazard Identify any electrical risks in the work area, such as overhead lines or other exposed electrical equipment and do not use the ladder where electrical risks occur.		X X																																															
23	Use non-conductive ladders for unavoidable live electrical work.		X	-																																														
	<table border="1"> <thead> <tr> <th>No.</th> <th>Item / Text</th> <th>Safety marking (Symbol)</th> <th>User instruction (Text or text and symbol)</th> <th>Symbol</th> </tr> </thead> <tbody> <tr> <td>24</td> <td>Do not use the ladder as a bridge.</td> <td></td> <td>X</td> <td>  </td> </tr> <tr> <td>25</td> <td>Do not modify the ladder design.</td> <td></td> <td>X</td> <td>-</td> </tr> <tr> <td>26</td> <td>Do not move a ladder while standing on it.</td> <td></td> <td>X</td> <td>-</td> </tr> <tr> <td>27</td> <td>For outdoor use caution to the wind.</td> <td></td> <td>X</td> <td>-</td> </tr> <tr> <td>28</td> <td>If a ladder is delivered with stabilizer bars and these bars should be fixed by the user before the first use this shall be described on the ladder and in the user instruction.</td> <td>X</td> <td>X</td> <td>  </td> </tr> <tr> <td>29</td> <td>Ladder for domestic use</td> <td>X</td> <td>X</td> <td>  </td> </tr> <tr> <td>30</td> <td>Ladder for professional use</td> <td>X</td> <td>X</td> <td>  </td> </tr> </tbody> </table>	No.	Item / Text	Safety marking (Symbol)	User instruction (Text or text and symbol)	Symbol	24	Do not use the ladder as a bridge.		X		25	Do not modify the ladder design.		X	-	26	Do not move a ladder while standing on it.		X	-	27	For outdoor use caution to the wind.		X	-	28	If a ladder is delivered with stabilizer bars and these bars should be fixed by the user before the first use this shall be described on the ladder and in the user instruction.	X	X		29	Ladder for domestic use	X	X		30	Ladder for professional use	X	X					P					
No.	Item / Text	Safety marking (Symbol)	User instruction (Text or text and symbol)	Symbol																																														
24	Do not use the ladder as a bridge.		X																																															
25	Do not modify the ladder design.		X	-																																														
26	Do not move a ladder while standing on it.		X	-																																														
27	For outdoor use caution to the wind.		X	-																																														
28	If a ladder is delivered with stabilizer bars and these bars should be fixed by the user before the first use this shall be described on the ladder and in the user instruction.	X	X																																															
29	Ladder for domestic use	X	X																																															
30	Ladder for professional use	X	X																																															
6.3.4	Leaning ladders				N/A																																													
6.3.5	Standing ladders				P																																													





EN 131-7: 2013

Clause	Requirement	Test	Result - Remark	Verdict																									
	Table 3 shows in addition to the basic requirements (see 6.3.3) the minimum requirements for safety marking, user instructions and the mandatory symbols for standing ladders.			P																									
	<p align="center">Table 3 — Additional requirements for safety marking and user instructions for standing ladders</p> <table border="1"> <thead> <tr> <th>No.</th> <th>Item / Text</th> <th>Safety marking (Symbol)</th> <th>User instruction (Text or text and symbol)</th> <th>Symbol</th> </tr> </thead> <tbody> <tr> <td>1</td> <td>Do not step off the side of standing ladder onto another surface.</td> <td align="center">X</td> <td align="center">X</td> <td></td> </tr> <tr> <td>2</td> <td>Open the ladder fully before use.</td> <td align="center">X</td> <td align="center">X</td> <td></td> </tr> <tr> <td>3</td> <td>Use the ladder with restraint devices engaged only.</td> <td></td> <td align="center">X</td> <td></td> </tr> <tr> <td>4</td> <td>Standing ladders shall not be used as a leaning ladder unless it is designed to do so.</td> <td></td> <td align="center">X</td> <td></td> </tr> </tbody> </table>			No.	Item / Text	Safety marking (Symbol)	User instruction (Text or text and symbol)	Symbol	1	Do not step off the side of standing ladder onto another surface.	X	X		2	Open the ladder fully before use.	X	X		3	Use the ladder with restraint devices engaged only.		X		4	Standing ladders shall not be used as a leaning ladder unless it is designed to do so.		X		P
No.	Item / Text	Safety marking (Symbol)	User instruction (Text or text and symbol)	Symbol																									
1	Do not step off the side of standing ladder onto another surface.	X	X																										
2	Open the ladder fully before use.	X	X																										
3	Use the ladder with restraint devices engaged only.		X																										
4	Standing ladders shall not be used as a leaning ladder unless it is designed to do so.		X																										
	<table border="1"> <thead> <tr> <th>No.</th> <th>Item / Text</th> <th>Safety marking (Symbol)</th> <th>User instruction (Text or text and symbol)</th> <th>Symbol</th> </tr> </thead> <tbody> <tr> <td>5</td> <td>Do not stand on the top two steps/rungs of a standing ladder without a platform and a hand/knee rail.</td> <td align="center">X</td> <td align="center">X</td> <td></td> </tr> <tr> <td>6</td> <td>Any horizontal surface which looks like a platform on a standing ladder that is not designed for standing on (e.g. a plastic work tray) shall be clearly indicated on that surface, (only if necessary due to design of ladder).</td> <td align="center">X</td> <td align="center">X</td> <td></td> </tr> </tbody> </table>			No.	Item / Text	Safety marking (Symbol)	User instruction (Text or text and symbol)	Symbol	5	Do not stand on the top two steps/rungs of a standing ladder without a platform and a hand/knee rail.	X	X		6	Any horizontal surface which looks like a platform on a standing ladder that is not designed for standing on (e.g. a plastic work tray) shall be clearly indicated on that surface, (only if necessary due to design of ladder).	X	X		P										
No.	Item / Text	Safety marking (Symbol)	User instruction (Text or text and symbol)	Symbol																									
5	Do not stand on the top two steps/rungs of a standing ladder without a platform and a hand/knee rail.	X	X																										
6	Any horizontal surface which looks like a platform on a standing ladder that is not designed for standing on (e.g. a plastic work tray) shall be clearly indicated on that surface, (only if necessary due to design of ladder).	X	X																										
6.3.6	Combination ladders			N/A																									
6.3.7	Extending ladders			N/A																									
6.3.8	Single or multi-hinge joint ladders			N/A																									
6.3.9	Telescopic ladders			N/A																									
6.3.10	Mobile ladders with platform			P																									

EN 131-7: 2013

Clause	Requirement	Test	Result - Remark	Verdict																									
	Table 8 shows in addition to the basic requirements (see 6.3.3) the additional requirements for safety marking, user instructions and the mandatory symbols for mobile ladders with platform.			P																									
	<p>Table 8 — Additional requirements for safety marking and user instructions for mobile ladders with platform</p> <table border="1"> <thead> <tr> <th>No.</th> <th>Item / Text</th> <th>Safety marking (Symbol)</th> <th>User instruction (Text or text and symbol)</th> <th>Symbol</th> </tr> </thead> <tbody> <tr> <td>1</td> <td>Do not step off the side of the mobile platform ladder onto another surface.</td> <td></td> <td>X</td> <td></td> </tr> <tr> <td>2</td> <td>Fully open before use (foldable mobile platform ladders).</td> <td>X</td> <td>X</td> <td></td> </tr> <tr> <td>3</td> <td>Use the ladder with restraint devices engaged only (only if necessary due to design of ladder).</td> <td></td> <td>X</td> <td></td> </tr> <tr> <td>4</td> <td>Any horizontal surface which looks like a platform on a mobile platform ladder that is not designed for standing on (e.g. a plastic work tray) shall be clearly indicated on that surface, (only if necessary due to design of ladder).</td> <td>X</td> <td>X</td> <td> EN ISO 7010-P024</td> </tr> </tbody> </table>			No.	Item / Text	Safety marking (Symbol)	User instruction (Text or text and symbol)	Symbol	1	Do not step off the side of the mobile platform ladder onto another surface.		X		2	Fully open before use (foldable mobile platform ladders).	X	X		3	Use the ladder with restraint devices engaged only (only if necessary due to design of ladder).		X		4	Any horizontal surface which looks like a platform on a mobile platform ladder that is not designed for standing on (e.g. a plastic work tray) shall be clearly indicated on that surface, (only if necessary due to design of ladder).	X	X	 EN ISO 7010-P024	P
No.	Item / Text	Safety marking (Symbol)	User instruction (Text or text and symbol)	Symbol																									
1	Do not step off the side of the mobile platform ladder onto another surface.		X																										
2	Fully open before use (foldable mobile platform ladders).	X	X																										
3	Use the ladder with restraint devices engaged only (only if necessary due to design of ladder).		X																										
4	Any horizontal surface which looks like a platform on a mobile platform ladder that is not designed for standing on (e.g. a plastic work tray) shall be clearly indicated on that surface, (only if necessary due to design of ladder).	X	X	 EN ISO 7010-P024																									

EN 131-7: 2013

Clause	Requirement	Test	Result - Remark			Verdict
	No.	Item / Text	Safety marking (Symbol)	User instruction (Text or text and symbol)	Symbol	
	5	Use only with stabilizer (if part of the ladder).	X	X	 <p>The symbol shows a particular design which might differ from the real product. The manufacturer may use a different symbol showing the particular design of his specific product.</p>	P
	6	Use only with ballast (if part of the ladder).	X	X	 <p>The symbol shows a particular design which might differ from the real product. The manufacturer may use a different symbol showing the particular design of his specific product.</p>	
	7	Use only with activated brakes (if part of the ladder).	X	X		
	8	Do not use ladders outdoors which are not intended for this purpose.	X	X		
						-
7 (EN 131-3)	Repair, maintenance and storage					N/T
Annex A (EN 131-3)	st of items to be inspected					P
Annex B (EN 131-3)	Storage (Informative)					P
7	Certification					-
	This standard may be a basis for a certification.					N/A
nnex A	Test sequence					P

----- End of Report -----